



# AiP74AC74

## Dual D Type Flip-Flop with Set and Reset; Positive-Edge Trigger

### Product Specification

**Specification Revision History:**

Version	Date	Description
2025-01-A0	2025-01	New
2025-05-A1	2025-05	Modify the parameters



# Contents

<b>1、 General Description.....</b>	<b>3</b>
<b>2、 Block Diagram And Pin Description .....</b>	<b>4</b>
2.1、 Block Diagram .....	4
2.2、 Pin Configurations.....	4
2.3、 Pin Description .....	5
2.4、 Function Table.....	5
<b>3、 Electrical Parameter .....</b>	<b>5</b>
3.1、 Absolute Maximum Ratings.....	5
3.2、 Recommended Operating Conditions.....	6
3.3、 Electrical Characteristics .....	6
3.3.1、 DC Characteristics .....	6
3.3.2、 AC Characteristics .....	7
<b>4、 Testing Circuit .....</b>	<b>7</b>
4.1、 AC Testing Circuit .....	7
4.2、 Test Data .....	8
4.3、 AC Testing Waveforms.....	8
4.4、 Measurement Points .....	8
<b>5、 Package Information .....</b>	<b>9</b>
5.1、 DIP14 .....	9
5.2、 SOP14 .....	10
5.3、 TSSOP14.....	11
<b>6、 Statements And Notes .....</b>	<b>12</b>
6.1、 The name and content of Hazardous substances or Elements in the product.....	12
6.2、 Notes .....	12



## 1、General Description

The AiP74AC74 is a dual edge triggered D-type flip-flop with individual data (nD) inputs, clock(nCP) inputs, set (nSD) and (nRD) inputs, and complementary nQ and nQ̄ outputs.

The set and rest are asynchronous active LOW inputs and operate independently of the clock input. Information on the data input is transferred to the nQ output on the LOW-to-HIGH transition of the clock pulse. The nD inputs must be stable one set-up time prior to the LOW-to-HIGH clock transition, for predictable operation.

### Features:

- Supply voltage range:2V to 6V
- Input levels: CMOS level
- Temperature range:-40°C to +125°C
- Packaging information: DIP14/SOP14/TSSOP14

### Ordering Information:

#### Tube packing specifications:

Part number	Packaging form	Marking code	Tube quantity	Boxed tube quantity	Boxed quantity	Notes
AiP74AC74DA14.TB	DIP14	74AC74	25 PCS/tube	40 tube/box	1000 PCS/box	Dimensions of plastic enclosure: 19.0mm×6.4mm Pin spacing: 2.54mm

#### Reel packing specifications:

Part number	Packaging form	Marking code	Reel quantity	Boxed reel quantity	Notes
AiP74AC74SA14.TR	SOP14	74AC74	4000 PCS/reel	8000 PCS/box	Dimensions of plastic enclosure: 8.7mm×3.9mm Pin spacing: 1.27mm
AiP74AC74TA14.TR	TSSOP14	74AC74	5000 PCS/reel	10000 PCS/box	Dimensions of plastic enclosure: 5.0mm×4.4mm Pin spacing: 0.65mm

Note: If the physical information is inconsistent with the ordering information, please refer to the actual product.



## 2、Block Diagram And Pin Description

### 2.1、Block Diagram

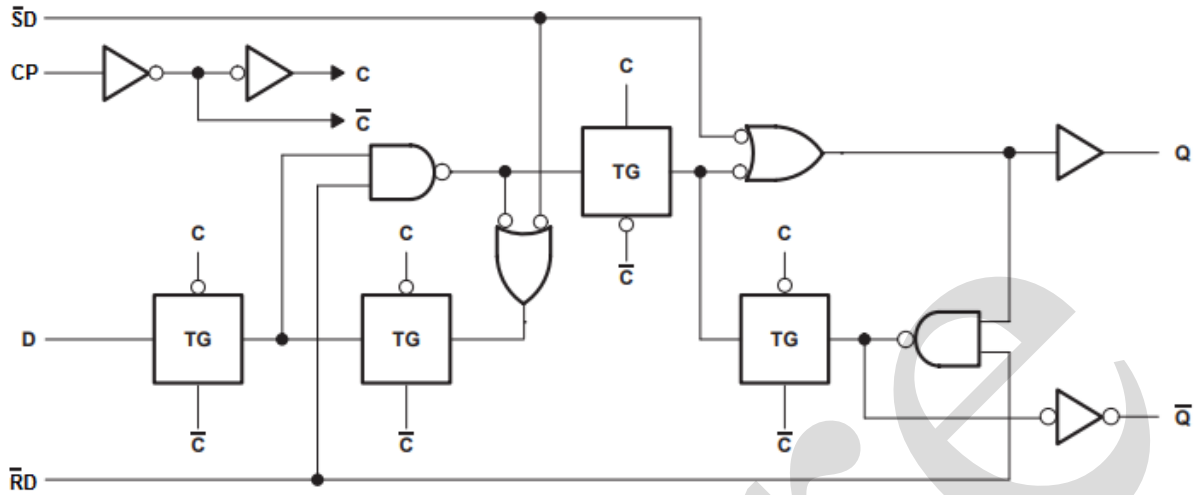

Figure 1. Logic symbol

### 2.2、Pin Configurations

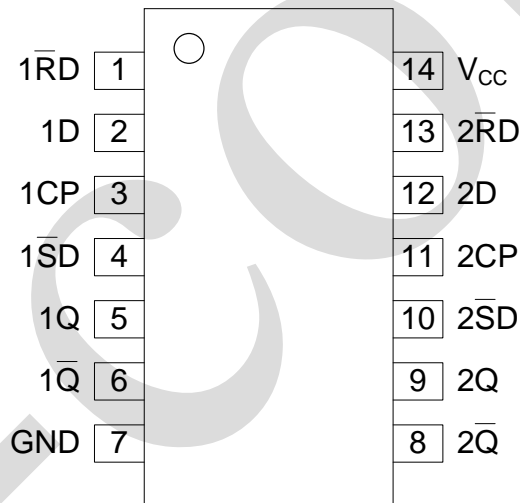

Figure 2. Pin configurations



## 2.3、Pin Description

Pin No.	Pin Name	Description
1	$\overline{1RD}$	data input
2	1D	data input
3	1CP	data input
4	$\overline{1SD}$	data input
5	1Q	data output
6	$\overline{1Q}$	data output
7	GND	ground (0V)
8	$\overline{2Q}$	data output
9	2Q	data output
10	$\overline{2SD}$	data input
11	2CP	data input
12	2D	data input
13	$\overline{2RD}$	data input
14	V <sub>CC</sub>	supply voltage

## 2.4、Function Table

Input				Output	
$\overline{nSD}$	$\overline{nRD}$	nCP	nD	nQ	$\overline{nQ}$
L	H	X	X	H	L
H	L	X	X	L	H
L	L	X	X	H	H
H	H	↑	H	H	L
H	H	↑	L	L	H

Note: H=HIGH voltage level; L=LOW voltage level.

## 3、Electrical Parameter

### 3.1、Absolute Maximum Ratings

(Voltages are referenced to GND (ground=0V), unless otherwise specified.)

Parameter	Symbol	Conditions	Min.	Max.	Unit
supply voltage	V <sub>CC</sub>	-	-0.5	+7	V
continuous supply current	I <sub>CC</sub>	-	-	200	mA
continuous ground current	I <sub>GND</sub>	-	-200	-	mA
input clamping current	I <sub>IK</sub>	V <sub>I</sub> <0V or V <sub>I</sub> >V <sub>CC</sub>	-	±20	mA
output clamping current	I <sub>OK</sub>	V <sub>O</sub> <0V or V <sub>O</sub> >V <sub>CC</sub>	-	±20	mA
continuous output current	I <sub>O</sub>	V <sub>O</sub> =0 to V <sub>CC</sub>	-	±50	mA
storage temperature	T <sub>stg</sub>	-	-65	+150	°C
soldering temperature	T <sub>L</sub>	10s	DIP	245	°C
			SOP/TSSOP	260	



## 3.2、Recommended Operating Conditions

Parameter	Symbol	Conditions	Min.	Typ.	Max.	Unit
supply voltage	$V_{CC}$	-	2	-	6	V
input voltage	$V_I$	-	0	-	$V_{CC}$	V
output voltage	$V_O$	-	0	-	$V_{CC}$	V
High-level output current	$I_{OH}$	-	-	-	-24	mA
Low-level output current	$I_{OL}$	-	-	-	24	mA
ambient temperature	$T_{amb}$	-	-40	-	+125	°C

## 3.3、Electrical Characteristics

### 3.3.1、DC Characteristics

( $T_{amb}=-40^{\circ}\text{C}$  to  $+125^{\circ}\text{C}$ , voltages are referenced to GND (ground=0V), unless otherwise specified.)

Parameter	Symbol	$V_{CC}$	Conditions	Min.	Typ.	Max.	Unit
HIGH-level input voltage	$V_{IH}$	3V	-	2.1	-	-	V
		4.5V	-	3.15	-	-	V
		5.5V	-	3.85	-	-	V
LOW-level input voltage	$V_{IL}$	3V	-	-	-	0.9	V
		4.5V	-	-	-	1.35	V
		5.5V	-	-	-	1.65	V
HIGH-level output voltage	$V_{OH}$	3V	$I_O=-50\mu\text{A}$	2.9	-	-	V
			$I_O=-12\text{mA}$	2.46	-	-	V
		4.5V	$I_O=-50\mu\text{A}$	4.4	-	-	V
			$I_O=-24\text{mA}$	3.76	-	-	V
		5.5V	$I_O=-50\mu\text{A}$	5.4	-	-	V
			$I_O=-24\text{mA}$	4.76	-	-	V
LOW-level output voltage	$V_{OL}$	3V	$I_O=-50\mu\text{A}$	-	0.002	0.1	V
			$I_O=-12\text{mA}$	-	-	0.44	V
		4.5V	$I_O=50\mu\text{A}$	-	0.001	0.1	V
			$I_O=24\text{mA}$	-	-	0.44	V
		5.5V	$I_O=50\mu\text{A}$	-	0.001	0.1	V
			$I_O=24\text{mA}$	-	-	0.44	V
input leakage current	$I_I$	5.5V	$V_I=V_{CC}$ or GND	-	-	$\pm 20$	$\mu\text{A}$
supply current	$I_{CC}$	5.5V	$V_I=V_{CC}$ or GND; $I_O=0\text{A}$	-	-	200	$\mu\text{A}$



3.3.2、AC Characteristics

( $T_{amb}=-40^{\circ}\text{C}$  to  $+125^{\circ}\text{C}$ , voltages are referenced to GND (ground=0V), unless otherwise specified.)

Parameter	Symbol	Conditions	Min.	Typ.	Max.	Unit	
Propagation delay	$t_{PLH}$	$\overline{nSD}$ or $\overline{nRD}$ to $nQ$ , $n\overline{Q}$ ; see Figure 4	$V_{CC}=3.3V$	3.5	8	12	ns
			$V_{CC}=5V$	2.5	6	9	
		$nCP$ to $nQ$ , $n\overline{Q}$ ; see Figure 4	$V_{CC}=3.3V$	4.5	8	13.5	
			$V_{CC}=5V$	3.5	6	10	
	$t_{PHL}$	$\overline{nSD}$ or $\overline{nRD}$ to $nQ$ , $n\overline{Q}$ ; see Figure 4	$V_{CC}=3.3V$	4	10.5	12	
			$V_{CC}=5V$	3	8	9.5	
$nCP$ to $nQ$ , $n\overline{Q}$ ; see Figure 4		$V_{CC}=3.3V$	3.5	8	14		
		$V_{CC}=5V$	2.5	6	10		
pulse time	$t_w$	Set or reset LOW; see Figure 5	$V_{CC}=3.3V$	5.5	-	-	
			$V_{CC}=5V$	4.5	-	-	
		Clock HIGH or LOW; see Figure 5	$V_{CC}=3.3V$	5.5	-	-	
			$V_{CC}=5V$	4.5	-	-	
set-up time	$t_{su}$	$nD$ to $nCP$ ; see Figure 5	$V_{CC}=3.3V$	4	-	-	
			$V_{CC}=5V$	3	-	-	
recovery time	$t_{rec}$	Set or reset; see Figure 5	$V_{CC}=3.3V$	0	-	-	
			$V_{CC}=5V$	0	-	-	
hold time	$t_h$	$nD$ to $nCP$ ; see Figure 5	$V_{CC}=3.3V$	0.5	-	-	
			$V_{CC}=5V$	0.5	-	-	

4、Testing Circuit

4.1、AC Testing Circuit

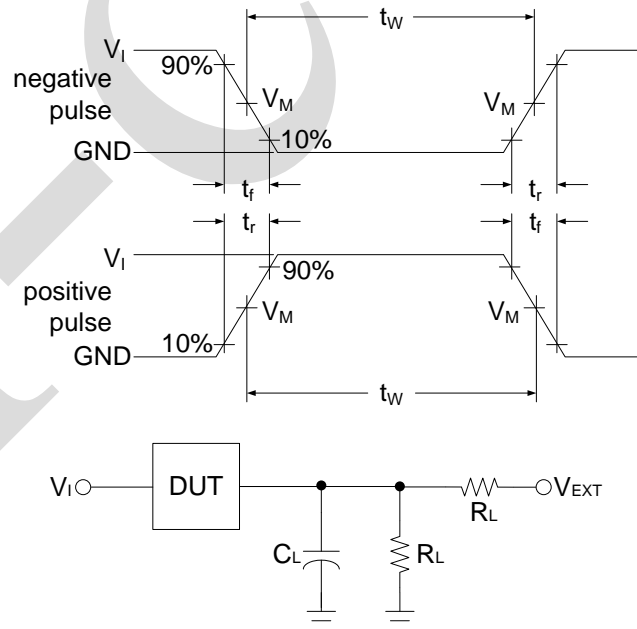

Figure 3. Test circuit for measuring switching times

$C_L$  includes probe and jig capacitance.



## 4.2、 Test Data

Supply voltage	Input		Load		V <sub>EXT</sub>
V <sub>CC</sub>	V <sub>I</sub>	t <sub>r</sub> = t <sub>f</sub>	C <sub>L</sub>	R <sub>L</sub>	t <sub>PLH</sub> /t <sub>PHL</sub>
3.3V to 5V	V <sub>CC</sub>	≤2.5ns	50pF	500Ω	Open

## 4.3、 AC Testing Waveforms

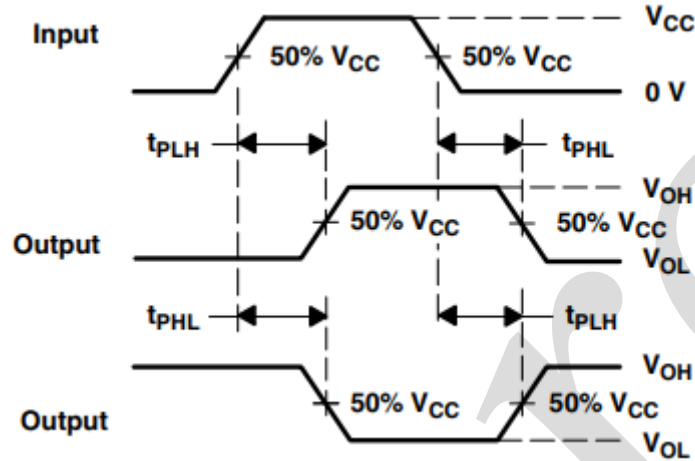

Figure 4. The clock input (nCP) to output (nQ, nQ) propagation delays

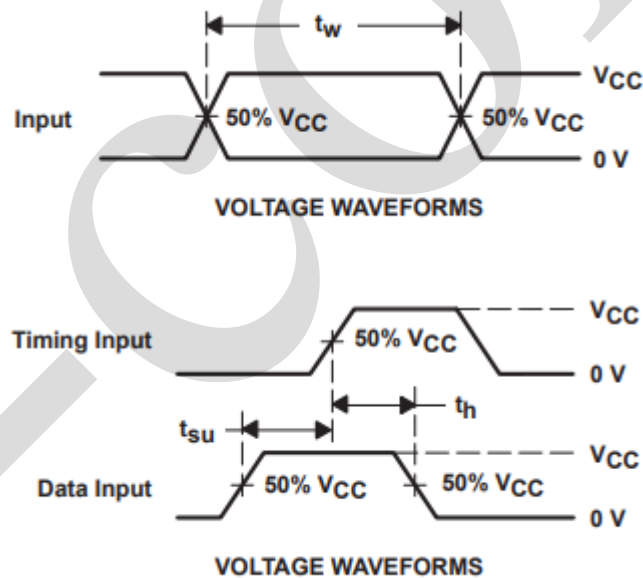

Figure 5. The set (nSD) and reset(nRD) to output (nQ, nQ) propagation delays, the set and reset pulse widths and the nRD to nCP recovery time

## 4.4、 Measurement Points

Supply voltage	Input	Output
V <sub>CC</sub>	V <sub>M</sub>	V <sub>M</sub>
3.3V to 5V	0.5×V <sub>CC</sub>	0.5×V <sub>CC</sub>



## 5、Package Information

### 5.1、DIP14

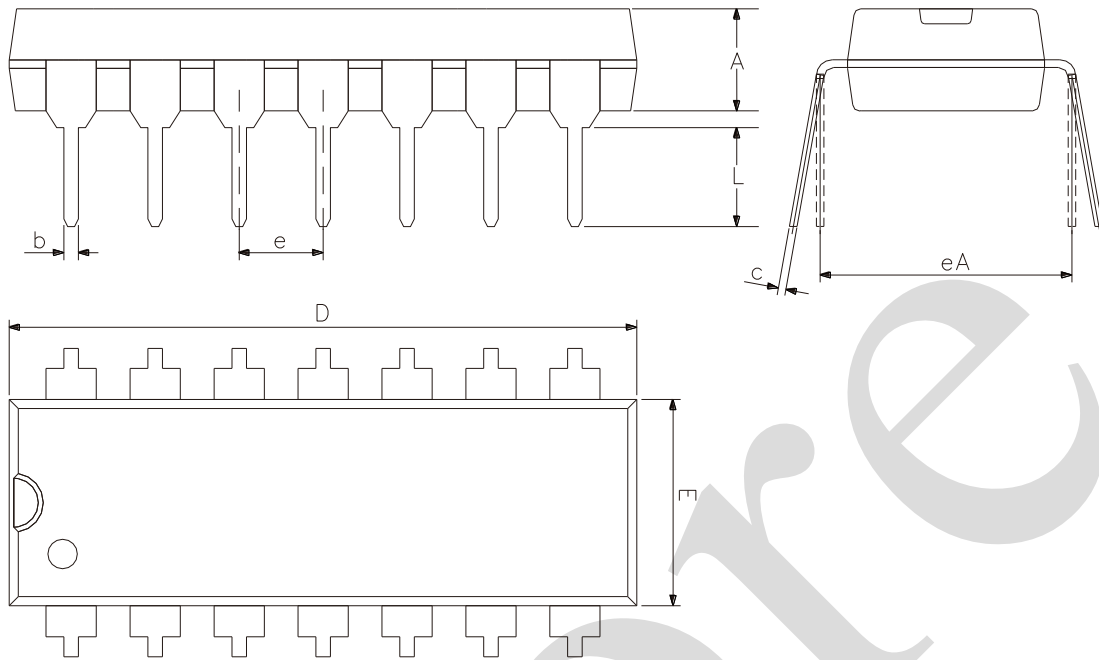

2023/12/A	Dimensions In Millimeters	
Symbol	Min	Max
A	3.05	3.60
b	0.33	0.56
c	0.20	0.36
D	18.80	19.40
E	6.20	6.60
e	2.54	
eA	7.62	10.90
L	2.92	—

Note: The package dimensions do not include flash and burrs, and the dimensions of flash and burrs shall not exceed 0.15mm.



## 5.2、SOP14

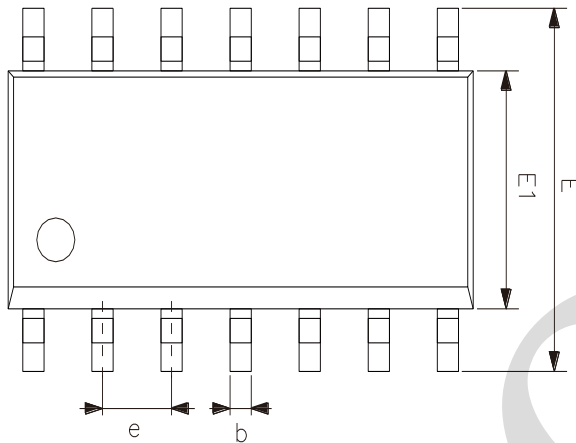
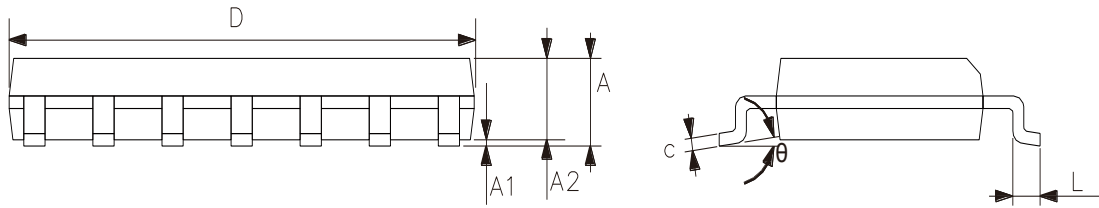

2023/12/A	Dimensions In Millimeters	
Symbol	Min.	Max.
A	1.50	1.75
A1	0.05	0.25
A2	1.30	—
b	0.33	0.50
c	0.19	0.25
D	8.43	8.76
E	5.80	6.25
E1	3.75	4.00
e	1.27	
L	0.40	0.89
$\theta$	0°	8°

Note: The package dimensions do not include flash and burrs, and the dimensions of flash and burrs shall not exceed 0.15mm.



## 5.3、TSSOP14

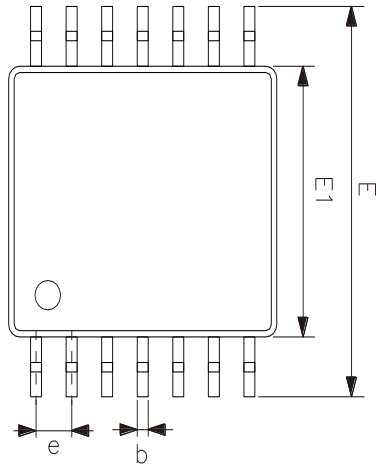
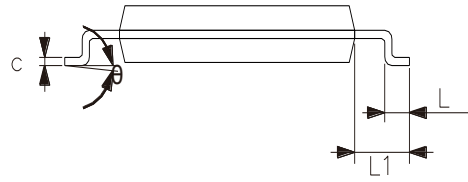
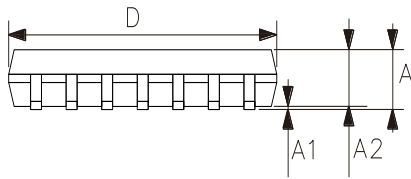

2023/12/A	Dimensions In Millimeters	
Symbol	Min	Max
A	—	1.20
A1	0.05	0.15
A2	0.80	1.05
b	0.19	0.30
c	0.09	0.20
D	4.90	5.10
E1	4.30	4.50
E	6.20	6.60
e	0.65	
L	0.45	0.75
L1	1.00	
$\theta$	0°	8°

Note: The package dimensions do not include flash and burrs, and the dimensions of flash and burrs shall not exceed 0.15mm.



## 6、 Statements And Notes

### 6.1、 The name and content of Hazardous substances or Elements in the product

Part name	Hazardous substances or Elements									
	Lead and lead compounds	Mercury and mercury compounds	Cadmium and cadmium compounds	Hexavalent chromium compounds	Polybrominated biphenyls	Polybrominated biphenyl ethers	Dibutyl phthalate	Butylbenzyl phthalate	Di-2-ethylhexyl phthalate	Diisobutyl phthalate
Lead frame	○	○	○	○	○	○	○	○	○	○
Plastic resin	○	○	○	○	○	○	○	○	○	○
Chip	○	○	○	○	○	○	○	○	○	○
The lead	○	○	○	○	○	○	○	○	○	○
Plastic sheet installed	○	○	○	○	○	○	○	○	○	○
explanation	○: Indicates that the content of hazardous substances or elements in the detection limit of the following the SJ/T11363-2006 standard. ×: Indicates that the content of hazardous substances or elements exceeding the SJ/T11363-2006 Standard limit requirements.									

### 6.2、 Notes

We recommend you to read this chapter carefully before using this product.

The information in this chapter is provided for reference only and i-Core disclaims any express or implied warranties, including but not limited to applicability, special application or non-infringement of third party rights.

This product is not suitable for critical equipment such as life-saving, life-sustaining or safety equipment. It is also not suitable for applications that may result in personal injury, death, or serious property or environmental damage due to product malfunction or failure. I-Core will not be liable for any damages incurred by the customers at their own risk for such applications.

The customer is responsible for conducting all necessary tests i-Core's application to avoid failure in the application or the application of the customer's third party users. I-Core does not accept any liability.

The Company reserves the right to change or improve the information published in this chapter at any time. The information in this chapter are subject to change without notice. We recommend the customer to consult our sales staff before purchasing.

Please obtain related materials form i-Core's regular channels and we are not responsible for its content if it is provided by sources other than our company.

In case of any conflict between the Chinese and English version, the version is subject to the Chinese one.